



Using Ultra Station to Create a Waveform with the DG1Z Arbitrary Waveform Generator

Date: 02.07.2014

Solution: Ultra Station is a software tool that allows user's to create, edit, and download arbitrary waveforms to Rigol's DG series of waveform generators.

In this application note, we will create a waveform and download it to a DG1062Z. The DG1Z models feature deep memory (8M standard and 16M expanded option) as well as SiFi technology. These two features allow unprecedented freedom in defining the data points and the sample rate for an arbitrary waveform.

First, I'd like to cover arbitrary waveform creation using an example. This will help develop a straight-forward approach to the waveform creation and provide a template for future arb creation.

Here is a waveform that we would like to create:

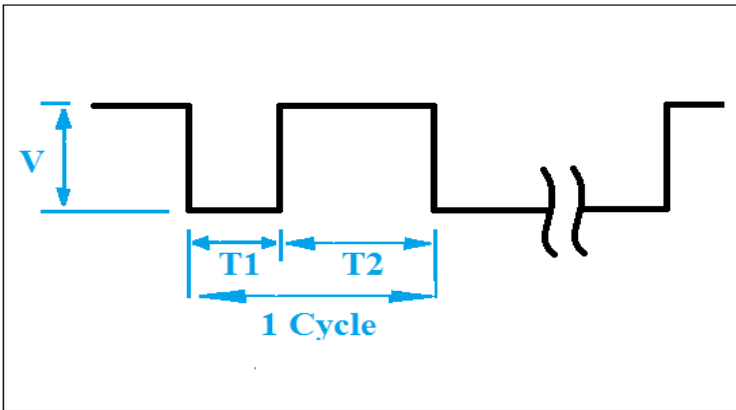

Where $V = 0-1V$, $T1 = 20\mu s$, and the Duty Cycle: $T1/(T1+T2) = 25\%$



Let's break the waveform into chunks and analyze each.

$$T1 = 20\text{us @ } 0\text{V}$$

$$\text{Duty Cycle} = 25\% = T1/(T1+T2)$$

$$25\%(T1+T2) = T1$$

$$T1 + T2 = T1/25\%$$

$$T2 = (T1/25\%) - T1$$

$$T2 = 20\text{us}/25\% - 20\text{us} = 60\text{us @ } 1\text{V}$$

$$T1 \text{ Time} = 20\text{us}$$

$$T2 \text{ Time} = 60\text{us}$$

$$\text{Total Time for Waveform} = T1 + T2 = 20\text{us} + 60\text{us} = 80\text{us}$$

Calculate the required Sample Rate

Now we know the total time for the waveform, let's calculate the sample rate.

First, let's take a look at the smallest feature that we want to replicate. In this case, that is the time delay T1. This is defined as 20us. More points/feature will provide higher resolution for the arbitrary waveform.

For this example, I am going to choose the number of points for the smallest feature as 1000.

Tip: Ultra Station requires waveforms are greater than 2100 points.

From here, we can calculate the sample rate with the following:

$$\text{Output Sample Rate} = \text{Samples/Time} = 1/(\text{Sample Interval})$$

$$\text{Sample interval} = \text{Time/Sample} = 20\text{us}/1000\text{points} = 0.02\text{us/point}$$

$$\text{Output Sample Rate} = 1/(\text{Sample Interval}) = 1/(0.02\text{us/point}) = 50\text{MSamples/s}$$

This is well within the DG1062Z 200MSa/s maximum sample rate capabilities. A few more calculations, and we will be ready to start building the wave.



Calculate the Number of Points

Now that we have the output sample rate, we can break down the waveform into chunks and determine how many points we will need.

Recall,

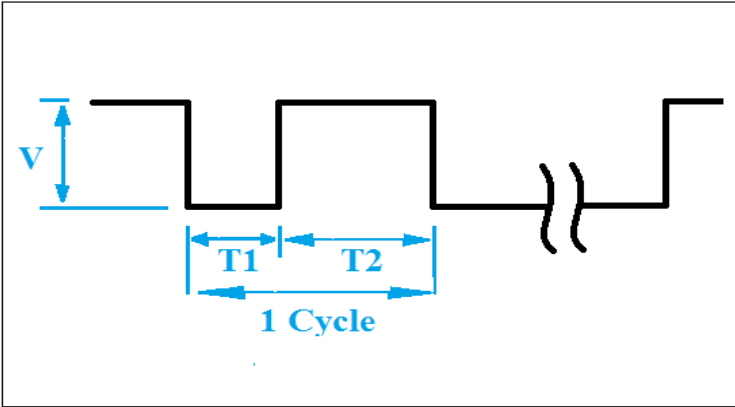

Where $V = 0-1V$, $T1 = 20\mu s @ 0V$, and $T2 = 60\mu s @ 1V$.

For $T1$, we have a flat $0V$ section for $20\mu s$. Based on our criteria for 1000 points for the smallest feature, we will need 1000 points for this chunk.

$$P_{T1} = 1000$$

Now, recall that the sample interval was selected at $2\mu s/\text{point}$. The time for chunk $T2$ time is $60\mu s$.

Therefore,

$$P_{T2} = \text{time}/\text{sample interval} = 60\mu s / (0.02\mu s/\text{point}) = 3000$$

$$\text{Total Points} = P_{T1} + P_{T2} = 1000 + 3000 = 4000$$

The DG1062Z has 8M points in standard memory and can be upgraded to 16M points. Again, we are well within the capabilities of the instrument.

To make the arb creation easier, it may be helpful to build a table of our waveform using the information that we have.

- The first chunk is from data point 0 to data point 999, for a total of 1000 points. It starts at 1V and all other points are 0V. The first point being 1V ensures that we start at the intended voltage.
- The second chunk is from data point 1000 to 3999, for a total of 3000 points. It starts and ends at 1V.



Here is the table of our data:

Chunk	Point	Voltage (V)
1	0	1
	1-999	0
2	1000 -3999	1

Also note, the Output Sample Rate = 50MSa/s

Now that we are organized, let's start building our waveform using UltraSigma.

1. Download and install both UltraSigma and Ultra Station software from the Rigol website
2. Power on the DG
3. Connect the DG to the controlling PC using a USB or Ethernet connection
4. Power on and connect an oscilloscope of appropriate bandwidth to the DG CH1 output
5. Start Rigol UltraSigma software
6. Right-click on the instrument you want to control and select Ultra Station

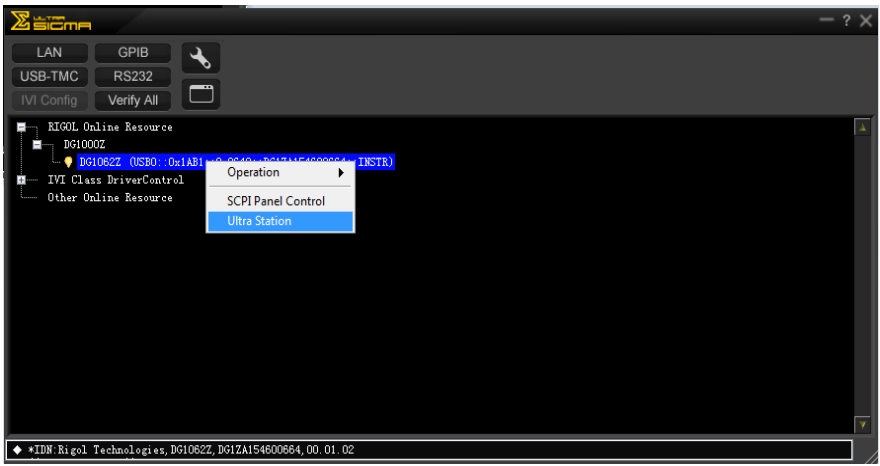



7. The UltraStation Splash Screen will come up



8. Select Create New File Icon





9. Set the Mode to Sample Rate (Srate), Points to 4000, Amplitude to 2Vpp, and Sample Rate to 5MSa/s. When you are finished, click OK.



10. This will bring up the main editing window.

Note: Voltage values on the X-Axis, Point numbers along the bottom





Remember our data table:

Chunk	Point	Voltage (V)
1	0	1
	1-999	0
2	1000 -3999	1

11. We can use the X1 and X2 Cursor controls (Under the Edit Tab) to block off an edit area

NOTE: X1 default location is point 0. X2 is the last point in the arb.

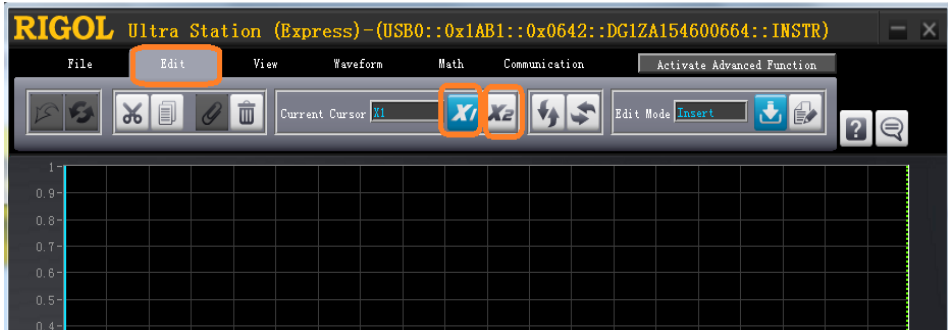



12. You can enter specific values for the location of each cursor by selecting the cursor (X1 in this case) and then double-clicking in the arb window. Then, you can enter the point values for each cursor.

In this example, our first point is located at 0 and has an amplitude of 1V. Points 1 through 999 have an amplitude of 0V.

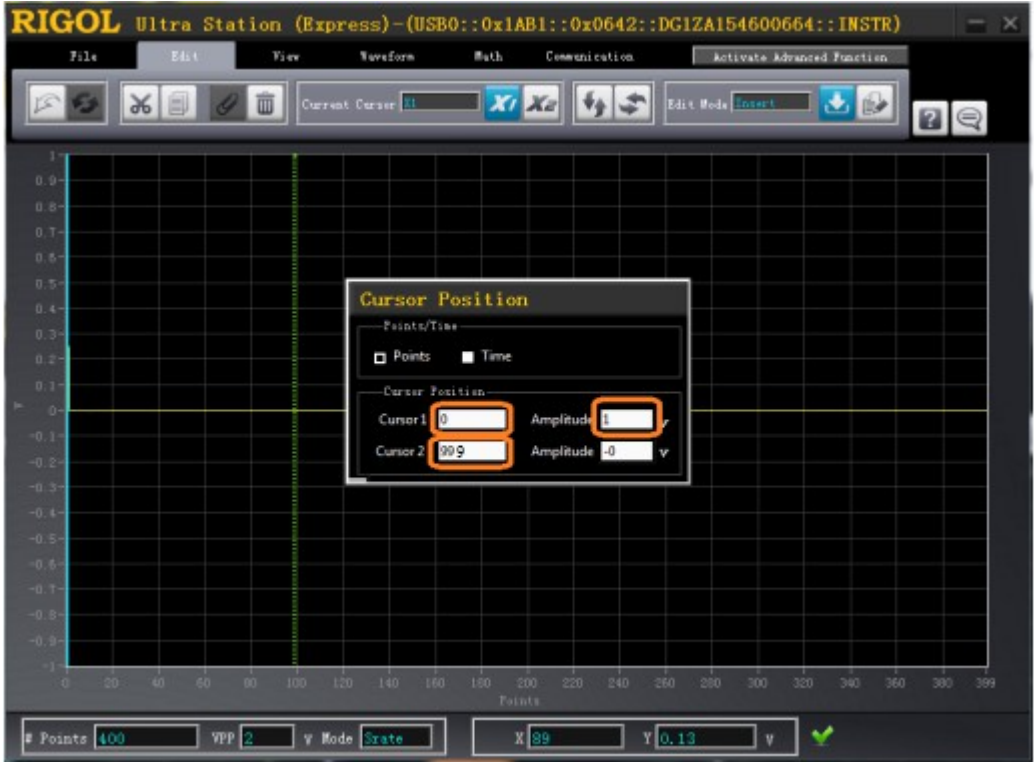

13. Press the Enter on the computer keyboard and then the ESC key to close the Cursor Position Window.



NOTE: You can zoom in to see the different areas using the Zoom Icons located in the View tab. Drag the Zoom cursor (White dotted box) using a right-click of the mouse.

You can also change the horizontal axis label to time by selecting the Time Coordinate icon.



Figure: Before Zoom



Figure: After Zoom. Note that the points shown are only to 47.



14. Zoom out by pressing the zoom out Icon.



15. Disable the Zoom by pressing the Zoom icon. It is deactivated when it is grey and active when it is shaded blue.

16. Now, let's move to Chunk 2. Points 1000 to 3999 have an amplitude of 1V. The best method to build a straight line is to use a standard waveform. In this case, DC will do just fine.

17. Select the Edit tab, and then double-click on the edit window again. Enter Cursor 1 position as 1000 and Cursor 2 position as 3999. Both amplitudes as 0V.

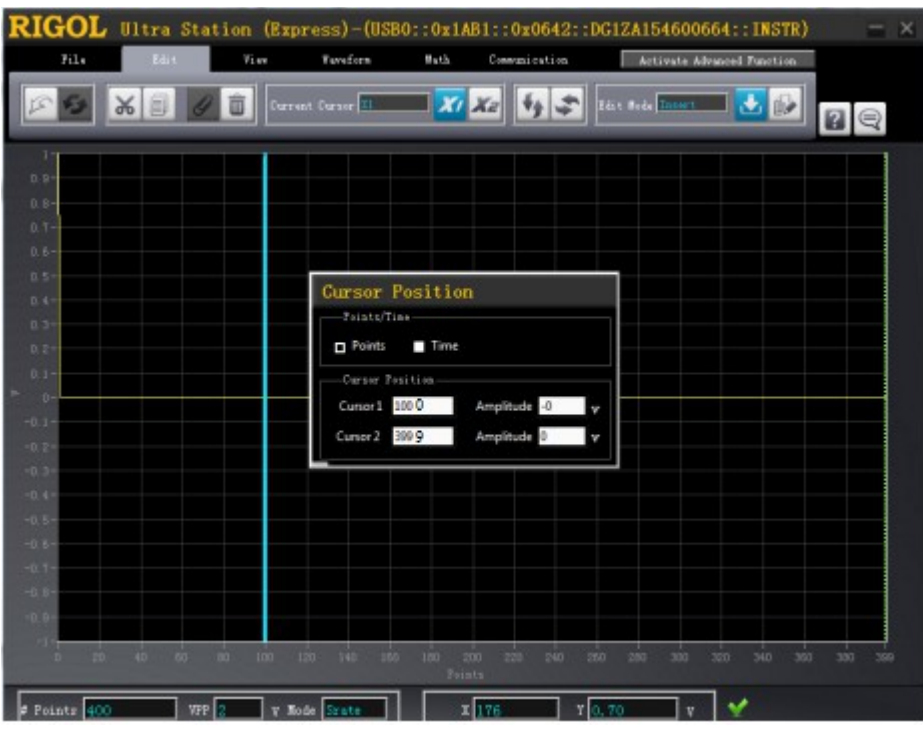

NOTE: Cursor 1 (Blue) and Cursor 2 (Green) have now moved to points 1000 and 3999 respectively.

18. Press the Enter on the computer keyboard and then the ESC key to close the Cursor Position Window.



19. Open the Standard Wave library by selecting the Insert Standard Wave icon on the Waveform tab.

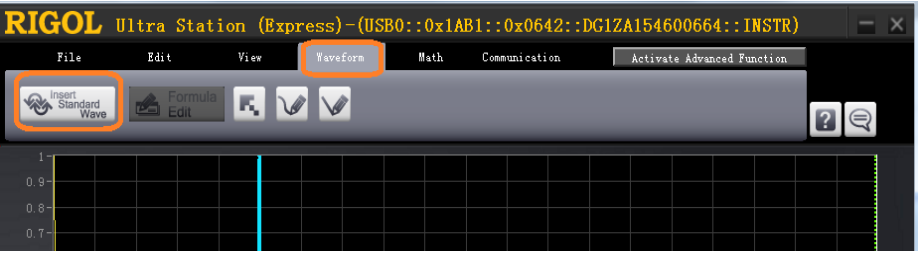

20. Select DC as the function, # Points to 3000, Check the box “To End” and set the offset to 1Vdc. Press OK.

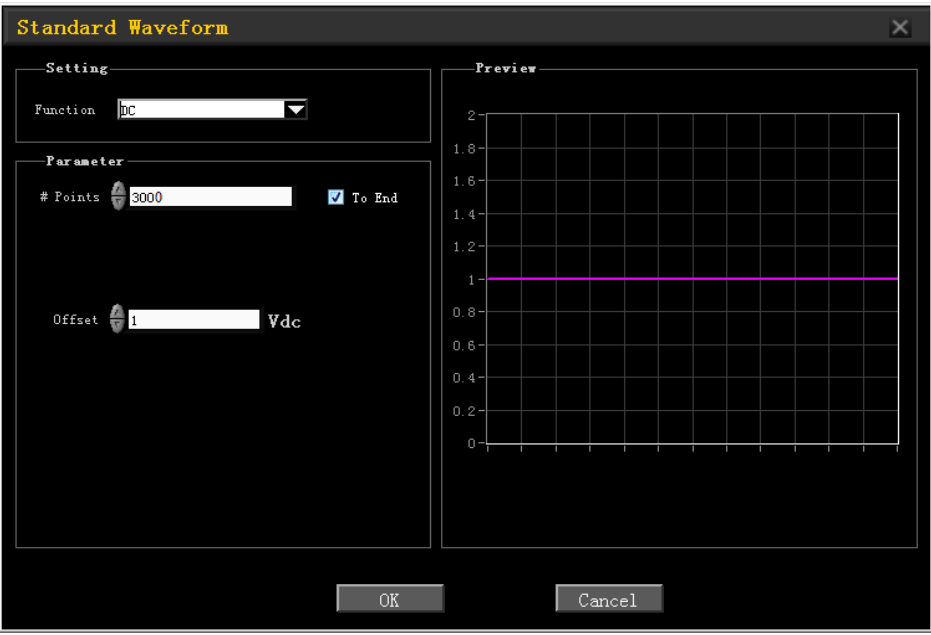



21. The waveform should look like we anticipated. The point 0 is 1V, 2 through 999 are 0V, and 1000 through 3999 are 1V.



NOTE: You can also change the horizontal axis label to time by selecting the Time Coordinate icon.

22. Now, let's download it to the DG1062Z. Select the Communication tab and then press the Download button.





23. You can select the channel to download to and the output state. Press OK to begin.

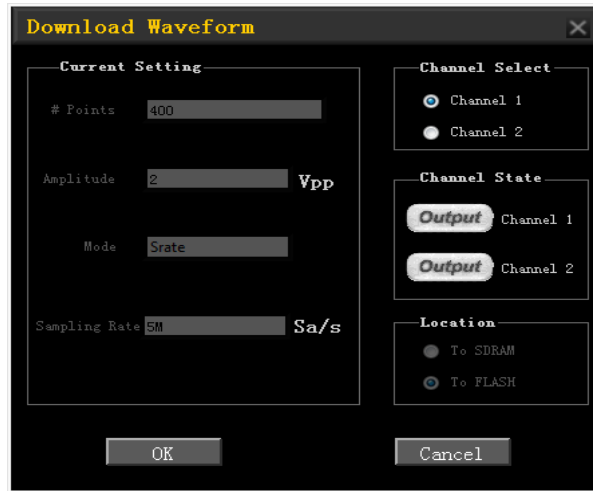

24. The DG1062Z should indicate that ARB has been selected by lighting the ARB Button.

25. You can enable local front panel control by pressing and holding the Help key on the front panel for ~ a second



26. Enable the output and check the waveform with a scope to be sure it is correct.

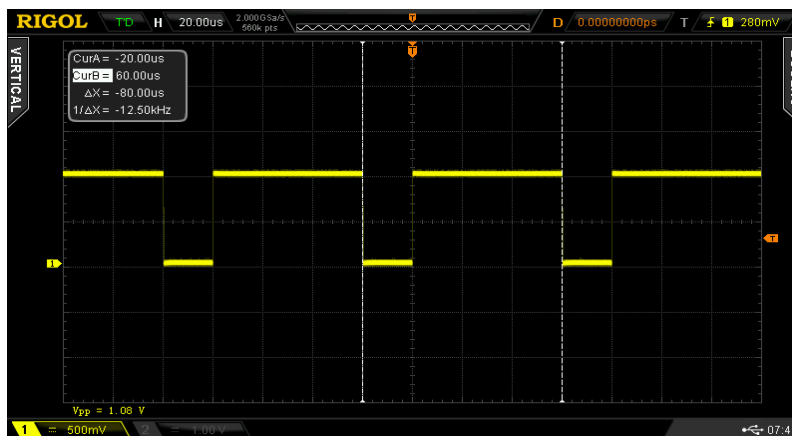



27. You can save waveforms as RAF files using Ultra Station. This will allow you to transfer the file to the DG1Z using a USB stick. RAF is the binary file used directly by the DG1Z family.

Select the File tab, Save As Icon and set the File Type to RAF. Press OK.

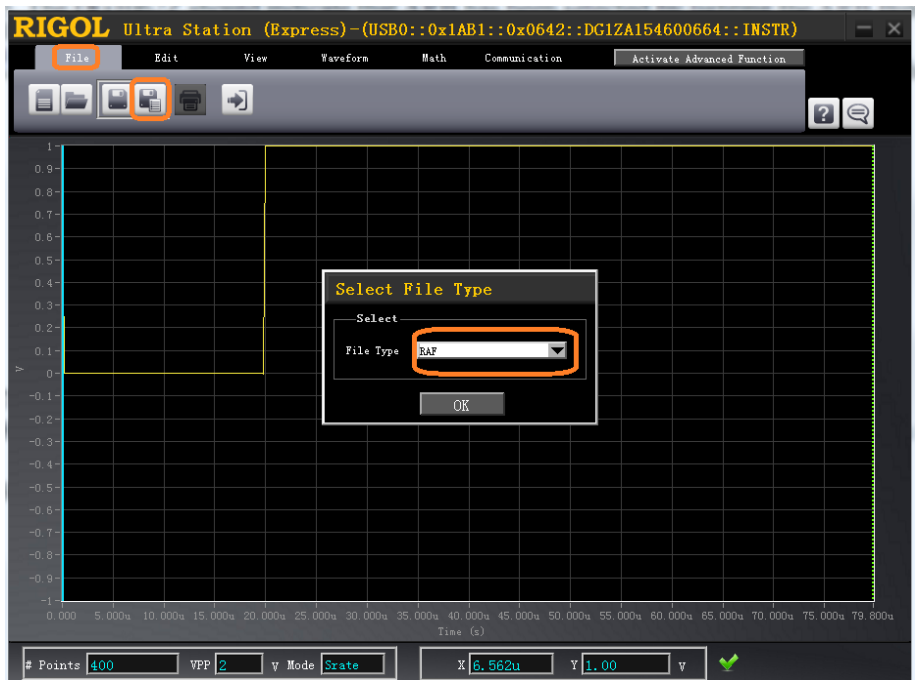



Other Editing Tips:

Line Draw

You can use Line Draw mode and the X and Y cursor values to draw lines between fixed points. Click the line draw icon located in the Waveform Tab and use the cursor locations to indicate the position of the pencil icon. Starting from left (smaller point number), click on the point you want the line to start at, then move to the right (bigger point number) and click again on the finishing point.

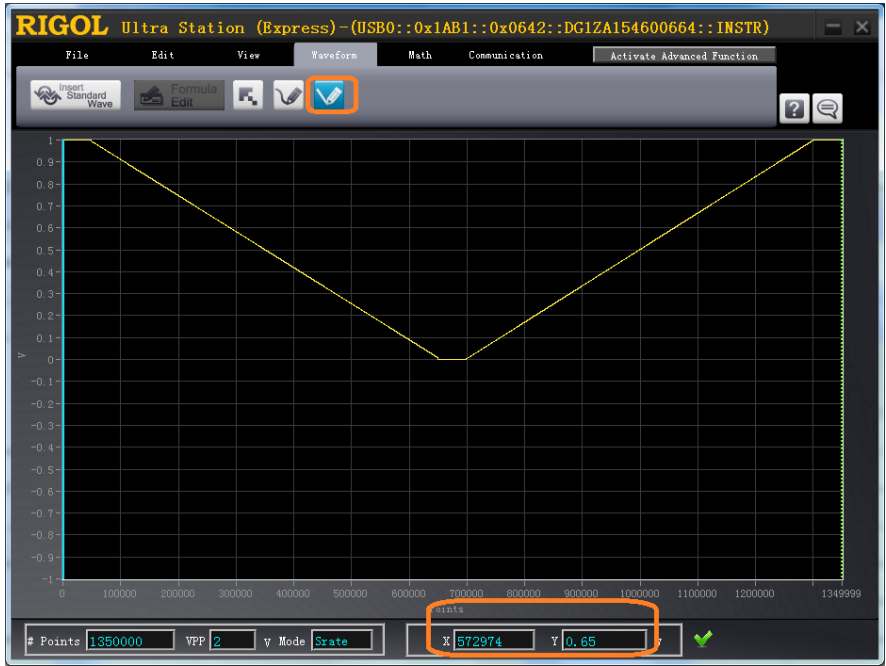



Undo/Redo/Copy/Paste/Cut:

The Edit tab contains standard editing functions.

- Cut (Scissor Icon)
- Copy (Paper Icon)
- Undo - Ctrl-Z
- Redo – Ctrl-Y
- You can also find a host of options by right-clicking in the waveform editing window:

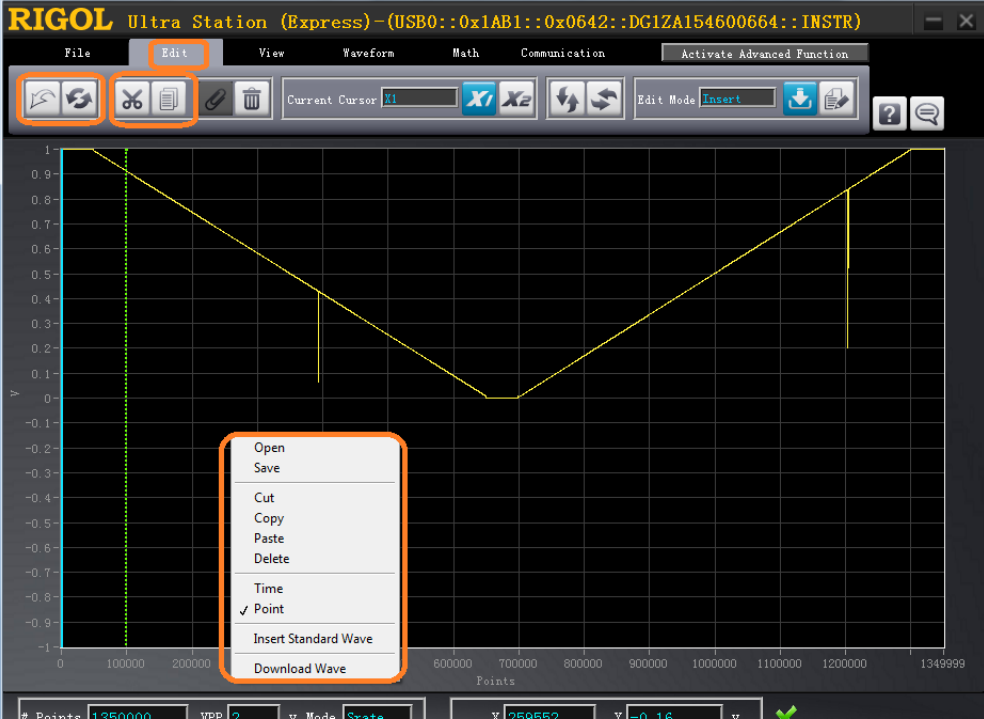



Headquarters

RIGOL TECHNOLOGIES, INC.
No.156,Cai He Village,
Sha He Town,
Chang Ping District, Beijing,
102206 P.R.China
Tel:+86-10-80706688
Fax:+86-10-80705070
Email: support@rigol.com

USA

RIGOL TECHNOLOGIES,USA INC.
7401 First Place, Suite N
Oakwood Village
OH 44164, USA
Toll free: 877-4-RIGOL-1
Office: (440) 232-4488
Fax: (216)-754-8107
Email: info@rigol.com

EUROPE

RIGOL TECHNOLOGIES GmbH
Lindbergh str. 4
82178 Puchheim
Germany
Tel: 0049- 89/89418950
Email: info-europe@rigoltech.com